



UNIMIG

OPERATING MANUAL

KUPJRRW80



2 YEARS Warranty
(Power Source)

Please read and understand this instruction manual carefully before the installation and operation of this equipment.

Thank you for your purchase of your UNIMIG PLASMA Cutting Machine.

We are proud of our range of welding equipment that has a proven track record of innovation, performance and reliability. Our product range represents the latest developments in Inverter technology put together by our professional team of highly skilled engineers. The expertise gained from our long involvement with inverter technology has proven to be invaluable towards the evolution and future development of our equipment range. This experience gives us the inside knowledge on what the arc characteristics, performance and interface between man and machine should be. Within our team are specialist welders that have a proven history of welding knowledge and expertise, giving vital input towards ensuring that our machines deliver control and performance to the utmost professional level. We employ an expert team of professional sales, marketing and technical personnel that provide us with market trends, market feedback and customer comments and requirements. Secondly they provide a customer support service that is second to none, thus ensuring our customers have confidence that they will be well satisfied both now and in the future.

UNIMIG welders and plasma cutters are manufactured to be compliant with - AS/NZ 60974-1, guaranteeing you electrical safety and performance.

WARRANTY

- 2 Years from date of purchase.
- Welding Guns of Australia Pty Ltd warranties all goods as specified by the manufacturer of those goods.
- This Warranty does not cover freight or goods that have been interfered with.
- All goods in question must be repaired by an authorised repair agent as appointed by this company.
- Warranty does not cover abuse, mis-use, accident, theft, general wear and tear.
- New product will not be supplied unless Welding Guns of Australia Pty Ltd has inspected product returned for warranty and agree's to replace product.
- Product will only be replaced if repair is not possible
- Please view full Warranty term and conditions supplied with machine or at www.unimig.com.au/warranty.asp or at the back of this manual.

CONTENTS	PAGE
Warranty	2
Safety - Cautions	4-6
Air Plasma Cutting Technology	7
Technical Data, Product Information	8
Machine Layout & Descriptions	9
Set Up and Operating Procedure	10-11
Plasma Cutting Procedure & Techniques	12-14
SC80 Plasma Torch Parts Breakdown	15
Machine Warranty	16-18

SAFETY



IMPORTANT: BEFORE INSTALLING, OPERATING OR CARRYING OUT MAINTENANCE ON THE PLASMA CUTTER, READ THE CONTENTS OF THIS MANUAL CAREFULLY, WHICH MUST BE STORED IN A PLACE FAMILIAR TO ALL USERS FOR THE ENTIRE OPERATIVE LIFE-SPAN OF THE MACHINE. PAY PARTICULAR ATTENTION TO THE SAFETY RULES. THIS EQUIPMENT MUST BE USED SOLELY FOR PLASMA CUTTING.

MACHINE OPERATING SAFETY

Plasma cutting equipment can be dangerous to both the operator and people in or near the surrounding working area, if the equipment is not correctly operated. Equipment must only be used under the strict and comprehensive observance of all relevant safety regulations. Read and understand this instruction manual carefully before the installation and operation of this equipment.



Electric shock: It can kill. Touching live electrical parts can cause fatal shocks or severe burns. The plasma nozzle and work circuit is electrically live whenever the output is on. The input power circuit and internal machine circuits are also live when power is on. Do not touch live electrical parts or electrodes with bare skin, gloves or wet clothing. Incorrectly installed or improperly grounded equipment is dangerous.

- Connect the primary input cable according to Australian and New Zealand standards and regulations.
- Disconnect power source before performing any service or repairs.
- Avoid all contact with live electrical parts of the welding circuit, torch nozzle and work piece with bare hands. The operator must wear dry welding gloves while he/she performs the plasma cutting task.
- Isolate yourselves from both the earth and the work piece.
- Keep cords dry, free of oil and grease, and protected from hot metal and sparks.
- Frequently inspect input power cable for wear and tear, replace the cable immediately if damaged, bare wiring is dangerous and can kill.
- Do not use damaged, under sized, or badly joined cables.
- Do not drape cables over your body.
- We recommend (RCD) safety switch is used with this equipment to detect any leakage of current to earth.



Fumes and gases are dangerous. Plasma cutting produces fumes and gases. Harmful fumes and metallic powders are produced during the cutting operation. Metals which are painted or coated or which contain mercury, zinc, lead and graphite may produce harmful concentrations of toxic fumes during cutting. Breathing these fumes and gases can be hazardous to your health.

- Do not breathe the smoke and gas generated whilst welding or cutting, keep your head out of the fumes
- Keep the working area well ventilated, use fume extraction or ventilation to remove welding fumes and gases.
- In confined or heavy fume environments always wear an approved air-supplied respirator. Cutting fumes and gases can displace air and lower the oxygen level causing injury or death. Be sure the breathing air is safe.
- Do not cut in locations near de-greasing, cleaning, or spraying operations. The heat and rays of the arc can react with vapours to form highly toxic and irritating gases.
- Materials such as galvanized, lead, or cadmium plated steel, containing elements that can give off toxic fumes when cutting. Do not cut these materials unless the area is very well ventilated, and or wearing an air supplied respirator.
- Always read the Material Safety Data Sheets (MSDS) that should be supplied with the material you are using. These MSDSs will give you the information regarding the kind and amount of fumes and gases that may be dangerous to your health.



Arc rays: harmful to people's eyes and skin. Arc rays from the plasma cutting process produce intense visible and invisible ultraviolet and infrared rays that can burn eyes and skin. Protect your eyes with welding masks or goggles fitted with filtered lenses, and protect your body with appropriate safety garments. Protect others by installing adequate shields or curtains.

- Always wear a helmet or goggles with correct shade of filter lens and suitable protective clothing including welding gloves, apron, leg and foot protection whilst the plasma cutting operation is performed.
- Measures should be taken to protect people in or near the surrounding working area. Use protective screens or barriers to protect others from flash, glare and sparks; warn others not to watch the arc.

Fire hazard. Plasma cutting on closed containers, such as tanks, drums, or pipes, can cause them to explode. Flying sparks from the welding arc, hot work piece, and hot equipment can cause fires and burns. Accidental contact of electrode to metal objects can cause sparks, explosion, overheating, or fire. Check and be sure the area is safe before doing any cutting.

- The cutting sparks may cause fire, therefore remove any flammable materials well away from the working area. Cover flammable materials and containers with approved covers if unable to be moved from the welding area.



• Do not Plasma Cut closed containers such as tanks, drums, or pipes, unless they are properly prepared according to the required Safety Standards to insure that flammable or toxic vapors and substances are totally removed, these can cause an explosion even though the vessel has been "cleaned". Vent hollow castings or containers before heating, cutting or welding. They may explode.

- Do not cut where the atmosphere may contain flammable dust, gas, or liquid vapours (such as petrol)
- Have a fire extinguisher nearby and know how to use it. Be alert that cutting sparks and hot materials from cutting can easily go through small cracks and openings to adjacent areas. Be aware that cutting on a ceiling, floor, bulkhead, or partition can cause fire on the hidden side.



Gas Cylinders. Do not cut in the vicinity of pressurised gas cylinders or in the presence of explosive dust, gases or fumes. Gas cylinders contain gas under high pressure. If damaged, a cylinder can explode. Because gas cylinders are normally part of the welding process, be sure to treat them carefully. CYLINDERS can explode if damaged.

- Protect gas cylinders from excessive heat, mechanical shocks, physical damage, slag, open flames, sparks, and arcs.
- Insure cylinders are held secure and upright to prevent tipping or falling over.
- Never allow the plasma nozzle or earth clamp to touch the gas cylinder, do not drape welding cables over the cylinder.
- Never plasma cut on a pressurised gas cylinder, it will explode and kill you.
- Open the cylinder valve slowly and turn your face away from the cylinder outlet valve and gas regulator.



Electronic magnetic fields. The magnetic fields created by the high currents generated by plasma cutting may affect the operation of pacemakers and other vital electronic medical equipment.

- Wearers of Pacemakers and other Implanted Medical Devices should keep away.
- Implanted Medical Device wearers should consult their doctor and the device manufacturer before going near any electric welding, cutting or heating operation.



Noise can damage hearing. Noise from some processes or equipment can damage hearing. This machine does not directly produce noise exceeding 80dB. The plasma cutting/welding procedure may produce noise levels beyond said limit; users must therefore implement all precautions required by law. Wear approved ear protection if noise level is high.



Hot parts. Items being plasma cut generate and hold high heat and can cause severe burns. Do not touch hot parts with bare hands. Allow a cooling period before working on the plasma torch. Use insulated welding gloves and clothing to handle hot parts and prevent burns.

CAUTION

1. Working Environment.

- 1.1 The environment in which this Plasma Cutter equipment is installed must be free of grinding dust, corrosive chemicals, flammable gas or materials etc, and at no more than maximum of 80% humidity.
- 1.2 When using the machine outdoors protect the machine from direct sun light, rain water and snow etc; the temperature of working environment should be maintained within -10°C to +40°C.
- 1.3 Keep this equipment 30cm distant from the wall.
- 1.4 Ensure the working environment is well ventilated.

2. Safety Tips.

2.1 Ventilation

This equipment is small-sized, compact in structure, and of excellent performance in amperage output. The fan is used to dissipate heat generated by this equipment during the welding operation.

Important: Maintain good ventilation of the louvers of this equipment. The minimum distance between this equipment and any other objects in or near the working area should be 30 cm. Good ventilation is of critical importance for the normal performance and service life of this equipment.

2.2 Thermal Overload protection.

Should the machine be used to an excessive level, or in high temperature environment, poorly ventilated area or if the fan malfunctions the Thermal Overload Switch will be activated and the machine will cease to operate. Under this circumstance, leave the machine switched on to keep the built-in fan working to bring down the temperature inside the equipment. The machine will be ready for use again when the internal temperature reaches safe level.

2.3 Over-Voltage Supply

Regarding the power supply voltage range of the machine, please refer to "Main parameter" table. This equipment is of automatic voltage compensation, which enables the maintaining of the voltage range within the given range. In case that the voltage of input power supply amperage exceeds the stipulated value, it is possible to cause damage to the components of this equipment. Please ensure your primary power supply is correct.

- 2.4 Do not come into contact with the output terminals while the machine is in operation. An electric shock may possibly occur.

MAINTENANCE

Exposure to extremely dusty, damp, or corrosive air is damaging to this plasma cutter. In order to prevent any possible failure or fault of this welding equipment, clean the dust at regular intervals with clean and dry compressed air of required pressure.

Please note that: lack of maintenance can result in the cancellation of the warranty; the warranty of this plasma cutting equipment will be void if the machine has been modified, an attempt to take apart the machine or open the factory-made sealing of the machine without the consent of an authorized representative of the manufacturer.

TROUBLE SHOOTING

Caution: Only qualified technicians are authorized to undertake the repair of this Plasma cutter equipment. For your safety and to avoid Electrical Shock, please observe all safety notes and precautions detailed in this manual.

Note:

- Our equipment as described in this manual conforms to all applicable rules and regulations of the 'Low Voltage Directive' (European Council Directive 73/23/EEC) as set out and amended by Council Directive 93/68/EEC) and to the National legislation for the enforcement of this Directive.
- Our equipment as described in this manual conforms to all applicable rules and regulations of the European Council Directive 89/336/EEC, (EMC Directive) and to the National legislation for the enforcement of this Directive.

AIR PLASMA CUTTING TECHNOLOGY

Plasma cutters work by passing an electric arc through a gas that is passing through a constricted opening. The gas can be air, nitrogen, argon, oxygen, etc. The electric arc elevates the temperature of the gas to the point that it enters a 4th state of matter. We all are familiar with the first three: i.e., Solid, liquid, and gas. Scientists call this additional state plasma. As the metal being cut is part of the circuit, the electrical conductivity of the plasma causes the arc to transfer to the work. The restricted opening (nozzle) the gas passes through causes it to squeeze by at a high speed, like air passing through a venturi in a carburettor. This high speed gas cuts through the molten metal.

Plasma cutting was invented as the result of trying to develop a better welding process. Many improvements then led to making this technology what it is today. Plasma cutters provide the best combination of accuracy, speed, and affordability for producing a variety of flat metal shapes. They can cut much finer, and faster than oxy-acetylene torches.

How a plasma cutter works:

Basic plasma cutters use electricity to superheat air into plasma (the 4th state of matter), which is then blown through the metal to be cut. Plasma cutters require a compressed air supply and AC power to operate.

Operation:

1. When the trigger is squeezed, DC current flows through the torch lead into the nozzle.
2. Next, compressed air flows through the torch head, through the air diffuser that spirals the air flow around the electrode and through the hole of the cutting nozzle.
3. A fixed gap is established between the electrode and the nozzle. (The power supply increases voltage in order to maintain a constant current through the joint.) Electrons arc across the gap, ionizing and super heating the air creating a plasma stream.
4. Finally, the regulated DC current is switched so that it no longer flows to the nozzle but instead flows from the electrode to the work piece. Current and airflow continue until cutting is stopped.

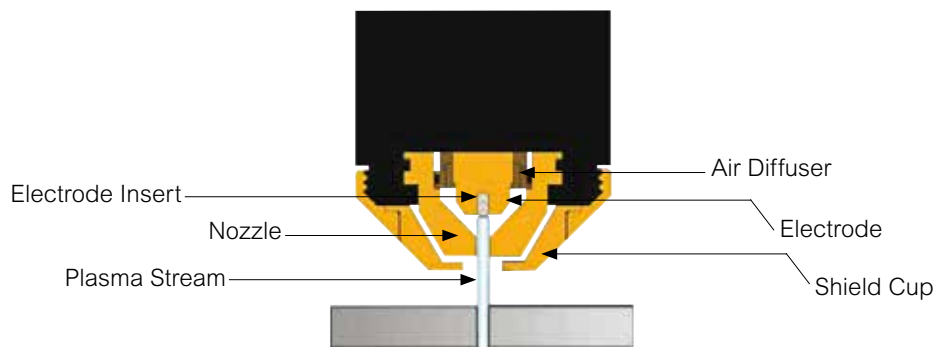

Notes:

The nozzle and electrode require periodic replacement. The electrode has an insert of tough high conductive material such as hafnium and cerium. This insert erodes with use, also the nozzle orifice will erode with use. Quality of the air used is paramount to longer life of electrodes and nozzles, in short clean dry air gives longer parts life, the cleaner and dryer the better. We recommend use of a Plasma Air Filter.

What kinds of materials can the plasma cut?

Virtually any metal can be plasma cut including steel, stainless steel, aluminium, brass, copper, etc. Any thickness from 30 gauge through 30mm can be cut, depending on the power of the plasma cutter used.

How Does Plasma Cutting Compare to Oxy-fuel (gas) cutting?

Plasma cutting can be performed on any type of conductive metal - mild steel, aluminium and stainless are some examples. With mild steel, operators will experience faster, thicker cuts than with alloys. Oxy-fuel cuts by burning, or oxidizing the metal it is severing. It is therefore limited to steel and other ferrous metals which support the oxidizing process. Metals like aluminium and stainless steel form an oxide that inhibits further oxidation, making conventional oxy-fuel cutting impossible. Plasma cutting however does not rely on oxidation to work and thus it can cut aluminium, stainless and any other conductive material. While different gasses can be used for plasma cutting, most people today use compressed air for the plasma gas. In most shops, compressed air is readily available, and thus plasma does not require fuel gas and compressed oxygen for operation. Plasma cutting is typically easier for the novice to master, and on thinner materials, plasma cutting is much faster than oxy-fuel cutting. However, for heavy sections of steel (25mm and greater), oxy-fuel is still preferred since oxy-fuel is typically faster and, for heavier plate applications high powered plasma machines are required for plasma cutting applications.

What are the limitations to Plasma Cutting? Where is Oxyfuel preferred?

The plasma cutting machines are typically more expensive than oxy/acetylene. Also, oxy/acetylene does not require access to electrical power or compressed air which may make it a more convenient method for some users. Oxyfuel can generally cut thicker sections (>25mm) of steel more quickly than plasma

RAZOR CUT 80

Plasma - 80 Amp Inverter Plasma Cutter

Cuts: Steels, Stainless, Cast Iron, Brass, Copper. Aluminium

UNIMIG
RazorCut
PLASMA CUT80

80 Amp - 30mm Cut on Mild Steel 415v Inverter Plasma Cutter Industrial Rated, Lightweight and Portable

Features

- Latest IGBT Inverter Technology
- CNC Connection
- Safe Euro torch connection
- High quality SC80 6 Metre Plasma torch
- Industrial application
- Tolerant to variable power supply
- In-built Air Regulator with preset air pressure
- Suitable to cut all electrically conductive materials
- Light weight and compact
- Strong metal housing, with plastic front and rear covers
- Generator use with pure sine wave generator only



Technical Data

Power Supply / Phases (V-Ph)	415 - 3 +/- 15%
Duty Cycle @ 104°F	40% @ 80Amps
Rated Power (KVA)	22
imax (A)	20
ieff (A)	12.6
Output Current Range (A) Plasma	20-80
Rated Output Voltage (V)	340
Insulation Class	F
Protection Class	IP21S
Plasma Arc Starting	Pilot L/F
Air Flow Pressure (MPA)	0.5 (75 psi)
Air Flow Rate l/min	189
Cutting Thickness - Clean (mm)	30
Cutting Thickness - Severance (mm)	35
Dimensions (mm)	560 x 220 x 415
Weight (Kgs)	16
Warranty	2 years machine only
Certification Approval	AS/NZS 60974-1



SC8050
Circle Cutting Kit
Option



50505-48
Sub-Micronic Cartridge
Option



50500-12
Sub-Micronic Air Filter
Option

Overview

The RAZORCUT80 is an inverter-based Plasma cutting machine produced using the latest in IGBT technology. This machine is reliable, robust and stacked with features that you can expect from a quality Industrial Plasma Cutter. The RAZORCUT80 produces a high temperature plasma stream providing effortless cutting of all electrically conductive materials including steel, cast iron, stainless steel, copper, aluminium brass etc. The RAZORCUT80 is equipped with a high quality SureGrip SC80 Plasma torch with Euro connection, developed specifically to enhance and improve the cut quality of the RAZORCUT80 machine. Connection of the SC80 Plasma torch provides effortless starting of the cut with powerful, fast and accurate cutting capability, additional is the benefit of longer life cycle consumable electrodes and cutting tips. The RAZORCUT80 is an exceptional machine that is suitable for a wide range of applications including Industrial use, sheet metal fabrication, site work, automotive, ducting work, repair and maintenance services. The RAZORCUT80 gives you the best of both worlds great portability, with the power to get the job done. Built to our specification and manufactured in compliance to AS/NZS 60974-1

Product Code: KUPJRRW80

Standard Package includes: RAZORCUT80 Machine, SC80 x 6m Plasma Torch, Earth Lead 4m, gas connection fitting



Front & Rear Panel Layout

Front Panel Layout



Rear Panel Layout



- | | | |
|----|--|---|
| 1 | | Power indicator. It illuminates when the machine is powered on, and it glitters after arc is successfully ignited. |
| 2 | | Overheating indicator. It illuminates when the working temperature of the machine is overly high. Meanwhile, the machine stops working. |
| 3 | | Digital Amperage metre |
| 4 | | 2T indicator. It illuminates when the machine is under 2T status. |
| | | 4T indicator: It illuminates when the machine is under 4T status. |
| 5 | | Gas-check indicator. It illuminates when the machine is under gas-check status. At this moment, the machine cannot cut. |
| | | Normal cutting mode, the machine can cut when this indicator illuminates. |
| 6 | | Air Pressure Gauge |
| 7 | | Amperage Control Dial. |
| 8 | | Output connector (DC+) connect to the work piece. |
| 9 | | Torch connection (DC-). |
| 10 | | Primary power input cable. |
| 11 | | On/Off switch. |
| 12 | | Air supply connector |

Set Up Procedure for PLASMA Cutting

(1) Connect the SC80 Plasma Torch to the machine. Insert the torch connection into the torch connection receptacle at the front of the machine and screw up hand tight.

Caution: Be careful not to bend the pins located inside the torch connector.

(2) Connect the earth lead to the output terminal of the machine and tighten.

(3) Connect the air supply to the air connection located at the rear of the machine.

Turn on the air supply

(4) Connect the machine to the correct power supply and switch on the machine using the on/off switch located at the rear of the machine.

(5) Select 2T / 4T operation

Operating procedure using the 2T / 4T Function with SC80 torch.

Set torch operation 2T / 4T.

- When 2T operation is selected press trigger Arc starts, release trigger Arc stops.
- When 4T operation is selected press and release trigger Arc starts, press and release trigger Arc stops.

(6) Set amperage dial.

1. Connect the SC80 Plasma Torch to the machine. Insert the torch connection into the torch connection receptacle at the front of the machine and screw up hand tight.

2. Connect the earth lead to the output terminal of the machine and tighten.



(1) Connect the SC80 Plasma Torch to the machine. Insert the torch connection into the torch connection receptacle at the front of the machine and screw up hand tight.

(2) Connect the earth lead to the output terminal of the machine and tighten.

Caution: Do not to bend the pins located inside the torch connector.



(3) Connect the air supply to the air connection located at the rear of the machine. Turn on the air supply.



(4) Connect the machine to the correct power supply and switch on the machine using the on/off switch located at the rear of the machine.



(5) select 2T or 4T torch control

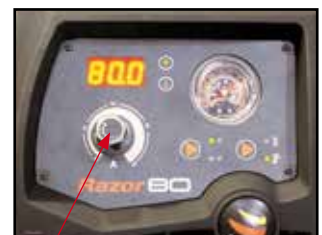

(6) Set the amperage dial

Operating Procedure for PLASMA Cutting

Operating procedure using the Stand Off Guide mounted to SC80 torch.

The feet of the standoff guide are placed on the cutting surface. This maintains an optimal 2mm standoff distance between the plasma cutting tip and the work, this is especially suitable if your hands are unsteady, or if you wish to use a straight edge guide or pattern guide. It also helps extend tip life.



1) Wear your safety gear. Generally you want the same type of protective gear as when welding. Plasma has high arc voltage if the job or bench is wet and you place your hand or arm on it you can become part of the circuit and receive a shock, be sure you are wearing leather gloves, Full length pants and covered shoes, Wear eye protection a #5 shade is the minimum eye protection with other shades required depending on amperage. A face shield is also recommended,

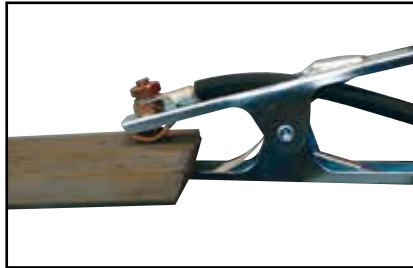

2) Connect the Earth Clamp securely to the work piece or the work bench.



3) Place and hold the torch vertical at the edge of the plate



4) Pull the trigger to energise the pilot arc. The cutting arc will start when the nozzle is moved closer to the edge of the work piece. When the cutting arc has cut through the edge of the plate start moving evenly in the direction you wish to cut,



5) Correct amperage and travel speed are important and relevant to material thickness and are correct when sparks are exiting from the work piece. If sparks are spraying up from the work piece there is insufficient amps selected or the travel speed is too fast.



6) To finish the cutting release the torch switch. The air flow will continue for 30 seconds to cool the torch head.

Cut Quality

A clean cut depends on several factors:

- amperage
- travel speed
- tip height & position
- tip and electrode quality
- air pressure and quality
- technique

The best quality cut will be produced when all these variables are set correctly for the material thickness and type of material being cut.

Poor quality cut



Good quality cut



Operating Procedure & Techniques for PLASMA Cutting

• Amperage

Standard rule of thumb is the thicker the material the more amperage required.

On thick material, set the machine to full output and vary your travel speed. On thinner material, you need to turn down the amperage and change to a lower-amperage tip to maintain a narrow kerf. The kerf is the width of the cut material that is removed during cutting.

• Speed

Amperage and speed are critical to producing a good quality cut. The faster you move (especially on aluminium), the cleaner your cut will be. To determine if you're going too fast or too slow, visually follow the arc that is coming from the bottom of the cut.

The arc should exit the material at a slight angle away from the direction of travel. If it's going straight down, that means you're going too slow, and you'll have an unnecessary buildup of dross or slag. If you go too fast, it will start spraying back onto the surface of the material without cutting all the way through. Because the arc trails at an angle, at the end of a cut, slow your cutting speed and angle the torch in to cut through the last bit of metal.

• Direction

It is easier to pull the torch towards you than push it. The plasma stream swirls as it exits the tip, biting one side and finishing off on the other leaving a bevelled edge and a straight edge. The bevel cut effect is more noticeable on thicker material and needs to be taken into consideration before starting your cut as you want the straight side of the cut to be on the finished piece you keep.

• Torch tip height & position

The distance and position of the plasma torch cutting tip has an affect on the quality of the cut and the extent of the bevel of the cut. The easiest way to reduce bevel is by cutting at the proper speed and height for the material and amperage that is being cut.

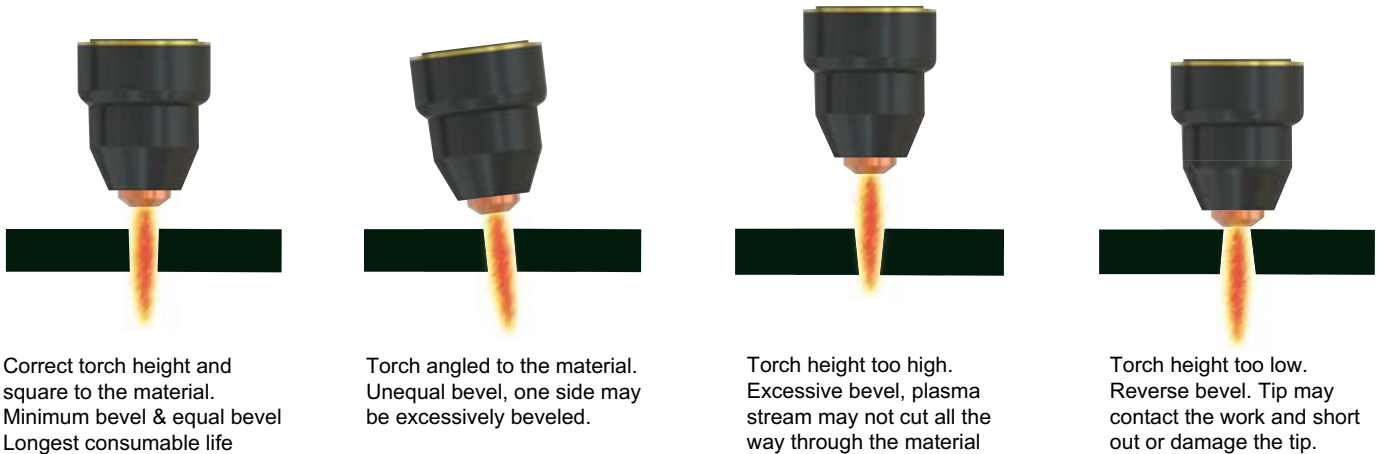

• Tip size and condition

The tip orifices focus the plasma stream to the work piece. It is important to use the correct size tip for the amperage being used, for example a tip with a 1.0mm orifice is good for 0-40 amps whereas a 1.3mm orifice is better for 40-80 amps. The low-amp tip has a smaller orifice which maintains a narrow plasma stream at lower settings for use on thin-gauge material. Using a 25 amp tip at an 80 amp setting will blow out and distort the tip orifice and require replacement. Conversely, using an 80-amp tip on the lower settings will not allow you to focus the plasma stream as well and creates a wide kerf. The condition of the tip orifice is critical to the quality of the cut result, a worn or damaged tip orifice will produce a distorted plasma stream resulting in a poor cut quality.

New Tip



Worn Tip



• Electrode condition

A fixed gap is established between the electrode and the inside of the cutting tip. Electrons arc across the gap, ionizing and super heating the air creating the plasma stream. The electrode contains an insert in the end made of a highly conductive material called hafnium. This insert erodes with use and develops a pit in the end of the electrode, when the pit becomes too much poor quality cuts will result and necessitate replacement of the electrode.

New Electrode



Worn electrode



Operating Procedure & Techniques for PLASMA Cutting

• Air pressure and volume

Air pressure, flow rate and air quality are critical to quality plasma cutting and consumable life span.

The required air pressure and volume can vary from model to model and the manufacturer will provide the specs.

The volume capacity of your compressor is important, if you have a small compressor with exactly the same l/min rating as the plasma, then the compressor will run continuously when you are plasma cutting, a compressor with a l/min rating slightly higher than the plasma would be more adequate. If you are doing a lot of cutting, cutting thick plate (same air consumption but slower cut speeds = longer cut time) then choose a compressor at 1.5 to 2 times the plasma system requirement.

• Air quality

Good air quality is essential to quality plasma cutting and consumable life span.

Compressors take in air at atmospheric pressure and increase the pressure and store it in a tank. Humidity in the air is condensed in the tank and in the airlines producing water, more so in humid environments. Moisture that forms in air lines has a tendency to condense into larger drops when the air pressure decreases as it is entering the plasma torch. When these droplets enter into the high temperatures (as much as 11,000°C) in the plenum of the torch, they immediately break down into oxygen and hydrogen, which alters the normal chemical content of air in the torch. These elements will then dramatically change the plasma arc which causes the torch consumable parts to wear very quickly, alters the shape of the nozzle orifice, dramatically affecting cut quality in terms of edge squareness, dross formation, and edge smoothness. Minimising the moisture in the air supply is absolutely critical to quality plasma cuts and longevity of consumable parts. As a minimum be sure to drain the receiver (tank) on the air compressor at least daily.

Most air plasma systems from reputable manufacturers have an on board particulate filter and or a coalescing filter with an auto drain that will remove some moisture from the air supply. For home workshop and light industrial users the on board air filter is adequate. Most situations however will require additional filtration to prevent moisture from affecting the quality of the plasma cutter and in most cases it is recommended to install a sub micronic particulate filter that is designed to trap water through absorption. This style of filter has a replaceable filter cartridge that absorbs water and must be changed after it is near saturation, it should be installed close as possible to the air intake of the plasma cutter.

Sub Micronic Filter



Filter Element



• Technique Tips

- It is easier to pull the torch through the cut than to push it.
- To cut thin material reduce the amperage until you get the best quality cut.
- Use the correct size tip orifice for the amperage being used.
- For Straight cuts use a straight edge or cutting buggy as a guide. For circles, use a template or circle cutting attachment.
- Check that the front end consumable parts of the plasma cutting torch are in good condition.

• Starting a cut



Hold the torch vertical at the edge of the work piece and place the cutting tip on the workpiece.



Pull the trigger to start the arc. Start cutting on the edge until the arc has cut completely through.



Then, proceed with the cut.

Operating Procedure & Techniques for PLASMA Cutting

• Piercing



Hold the torch at an angle to the work piece, pull the trigger to start the arc and slowly rotate it to an upright position.



When sparks are exiting from the bottom of the work piece, the arc has pierced through the material.



When the pierce is complete, proceed with cutting.

• Safety Trigger Operation

The Suregrip SC80 torch supplied with the RazorCut machine has a new design of safety trigger. Just pull back on the trigger whilst increasing your grip and you will feel the trigger move to the on position. When you release the pressure it will return to the off position.



off



on



off

PLASMA CUTTING TORCHES

SC80 Plasma Torch & Spares

Air Cooled 80 Amp



Rating: 80A Air/N₂ Gas, @ 60% duty cycle.

For use on **RAZORCut 45 KUPJRRW45** & **RAZORCut 80 KUPJRRW80**

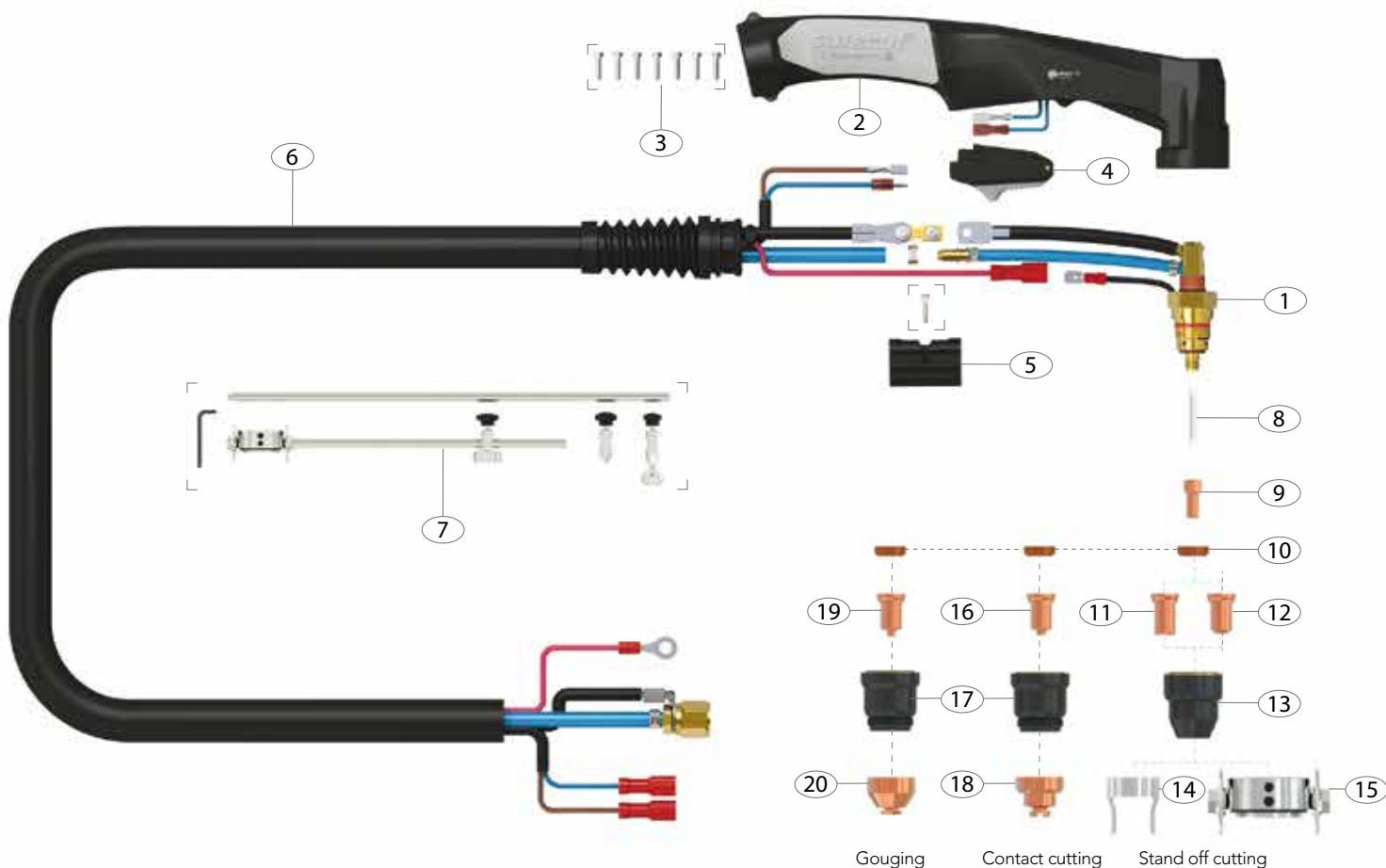

Torch Model	Description	Part Number
6 Mt	Surecut™ Plasma Cutting Torch Package	WG-SC80-60-CC1

Front end consumables

Torch Spare Parts		
No	WGA Part No.	Description
1	SC8001	SC80 70 Torch Head Kit
2	SC8014	Plasma Handle Kit
3	SCSP1	Screw Pack
4	SC2516	Plasma Safety Trigger
5	SC8015	Location Block
6	SC8019-60-CF4	Cable Assembly Complete X 6mt
7	SC8050	Circle Cutting Attachment Kit

Wear Spare Parts		
No	WGA Part No.	Description
8	SC8002	Cooling Tube
9	SC8004	Electrode
10	SC8006	Swirl Ring
11	SC8020-09	Cutting Tip 0.9mm
12	SC8020-10	Cutting Tip 1.0mm 40-50A
	SC8020-13	Cutting Tip 1.3mm 70-80A
13	SC8030	Retaining Cup
14	SC8040	Stand Off Guide
15	SC8051	Cutting Buggy
16	SC8026-10	Cutting Tip Contact 1.0mm
	SC8026-11	Cutting Tip Contact 1.1mm
	SC8026-12	Cutting Tip Contact 1.2mm
	SC8026-13	Cutting Tip Contact 1.3mm
17	SC8031	Shield Cap Body
18	SC8041	Shield Cap
19	SC8028-16	Gouging Tip 1.6mm
20	SC8043	Shield Cap Gouging

Welding Guns Of Australia Pty Ltd ('Us', 'We') warrants that the following products under UNI-MIG, RAZORWELD, UNI-TIG, UNI-PLAS, UNI-FLAME, XCEL-ARC, TECNA, T&R, HIT-8SS & ROTA, supplied by Us and purchased by you from an Authorised UNI-MIG, RAZORWELD, UNI-TIG, UNI-PLAS, UNI-FLAME, XCEL-ARC, TECNA, T&R, HIT-8SS & ROTA Dealer throughout Australia are free of Material and Faulty Workmanship defects except for those products listed under 'Warranty Exclusions'.

These terms and conditions supersede and exclude all former and other representations and arrangements relating to any warranties on these products.

WARRANTY PERIOD

We offer the following 'Warranty Periods' from 'date of purchase':

An Extended Warranty Period of 6 months total shall apply only to Machinery where offered and warranty is registered online.

UNI-MIG Viper Range (Power Source Only)	1 Year	(Clause 3)
UNI-MIG Minimig Series (Power Source Only)	2 Years	(Clause 3)
UNI-MIG RAZORWELD Series (Power Source Only)	3 Years	(Clause 1&3)
UNI-MIG Procraft Series (Power Source Only)	3 Years	(Clause 1&3)
UNI-MIG Trade Series (Power Source Only)	3 Years	(Clause 1&3)
UNI-MIG Trade Series SWF (Power Source / Separate Wire Feeder Only)	3 Years	(Clause 1&3)
UNI-MIG Workshop Series (Power Source Only)	3 Years	(Clause 1&3)
UNI-MIG Workshop Series SWF (Power Source / Separate Wire Feeder Only)	3 Years	(Clause 1&3)
UNI-MIG Jasic DC MMA/TIG (Power Source Only)	3 Years	(Clause 3)
UNI-MIG Jasic Inverter MIG (Power Source Only)	3 Years	(Clause 3)
UNI-MIG Jasic Inverter MIG SWF (Power Source / Separate Wire Feeder Only)	3 Years	(Clause 3)
UNI-TIG Jasic Inverter TIG (Power Source Only)	3 Years	(Clause 3)
UNI-MIG Water Cooler	1 Year	(Clause 3)
T&R Pulse MIG (Power Source Only)	2 Year	(Clause 3)
T&R Pulse MIG SWF (Power Source / Separate Wire Feeder Only)	2 Year	(Clause 3)
UNI-PLAS (Power Source Only)	3 Years	(Clause 3)
UNI-PLAS Jasic Series (Power Source Only)	2 Years	(Clause 3)
UNI-PLAS Site Cut Series (Power Source Only)	1 Year	(Clause 3)
UNI-FLAME Gas Cutting and Welding Kits	3 Months	(Clause 2&3)
UNI-FLAME Straight Line & Gas Cutting Machines (Power Source Only)	1 Year	(Clause 3)
UNI-FLAME Regulators Argon/ Acetylene / Oxygen / LPG / Bobbin Flowmeter	1 Year	
UNI-FLAME Automatic Welding Helmet	2 Years	
UNI-MIG / RAZORWELD Automatic Welding Helmets	2 Years	
TECNA (Power Source Only)	1 Year	(Clause 3)
HIT-8SS Automatic Carriage (Power Source Only)	1 Year	(Clause 3)
ROTA 102 Rotating table	1 Year	
HOTBOX ElectrodeOven	1 Year	
SPOTCAR 3500	1 Year	(Clause 3)
TORCHES -GMAW, GTAW, MMAW, PLASMA, EARTH LEADS, INTERCONNECTING CABLES, GAS HOSE	3 Months	(Clause 3)

(Clause 1) 3 year warranty on transformers, inductor and rectifier. 1 year warranty on PCB, and all other components.

(Clause 2) Gas Hose, Flashbacks are subject to and covered by the Manufacture's Individual Warranty, Contact the manufacturer for details.

(Clause 3) This only Covers Manufactures defaults on all accessories for the first three months after date of purchase.

WARRANTY / RETURNS / EXCHANGES

We understand that sometimes you may need to return a product you have purchased from Welding Guns Of Australia PTY LTD Authorised Dealer Network, to assist you, we have set out below the Welding Guns Of Australia PTY LTD Returns Policy that you should know.

Our Returns Policy includes the rights you have under the Australian Consumer Law and other relevant laws. Your Rights under the Australian Consumer Law - Our goods come with guarantees that cannot be excluded under the Australian Consumer Law. You are entitled to a replacement or refund for a major failure and for compensation for any other reasonably foreseeable loss or damage. You are also entitled to have the goods repaired or replaced if the goods fail to be of acceptable quality and the failure does not amount to a major failure.

- You shall inspect the Goods on delivery and shall within seven (7) days of delivery (time being of the essence) notify Welding Guns Of Australia PTY LTD of any alleged defect, shortage in quantity, damage or failure to comply with the description or quote.
- You shall also afford Welding Guns Of Australia PTY LTD the opportunity to inspect the Goods within a reasonable time following delivery if you believe the Goods are defective in any way.
- If you shall fail to comply with these provisions the Goods shall be presumed to be free from any defect or damage. For defective Goods, which Welding Guns Of Australia PTY LTD has agreed in writing that you are entitled to reject, Welding Guns Of Australia PTY LTD liability is limited to either (at the Welding Guns Of Australia PTY LTD discretion) replacing the Goods or repairing the Goods except where you have acquired Goods as a consumer within the meaning of the Trade Practices Act 1974 or the Fair Trading Acts of the relevant state or territories of Australia, and is therefore also entitled to, at the consumer's discretion either a refund of the purchase price of the Goods, or repair of the Goods, or replacement of the Goods.

Returns will only be accepted provided that:

- (a) You have complied with the provisions outlined above, and
- (b) where the Goods are unable to be repaired, the Goods are returned at your cost within thirty (30) days of the delivery date, and
- (c) Welding Guns Of Australia PTY LTD will not be liable for Goods which have not been stored or used in a proper manner, and
- (d) the Goods are returned in the condition in which they were delivered and with all packaging material, brochures and instruction material in as new condition as is reasonably possible in the circumstances.

- Welding Guns Of Australia PTY LTD Accepts no responsibility for products lost, damaged or mislaid whilst in transit
- Welding Guns Of Australia PTY LTD may (at their sole discretion) accept the return of Goods for credit but this may incur a handling fee of up to fifteen percent (15%) of the value of the returned Goods plus any freight costs.
- Where a failure does not amount to a major failure, Welding Guns Of Australia PTY LTD is entitled to choose between providing you with a repair, replacement or other suitable remedy.
- Your rights under the Australian Consumer Law are not limited by a defined time. However, the Australian Consumer Law does recognise that the relevant time period can vary from product to product, depending on factors such as the nature of the product and the price. Welding Guns Of Australia PTY LTD adopts the same approach. As you can appreciate, the type of remedy we can offer you may also vary depending on how long it takes you to return the product to us.

MAKING A CLAIM

If you wish to make a claim under this Warranty, you should:

- Return the product to the point of purchase either in person or on a prepaid courier; or
- Contact Us by Telephone

Sydney Head Office: 02 9870 4200 or Mail PO Box 3033 Lansvale NSW 2166.
Queensland: 07 3333 2855
Victoria: 03 8682 9911
Western Australia: 08 6363 5111

When returned, the product must be accompanied with the original invoice including the purchase price and disclosing the purchase date

All costs of installation, cartage, freight, travelling expenses, hiring tools and insurance are paid by the Customer.

To the extent permitted by law, our total liability for loss or damage of every kind related to the product in any way whatsoever is limited to the amount paid to the retailer by you for the product or the value of the product.

No responsibility will be taken for products lost, damaged or mislaid whilst in transit.

WARRANTY EXCLUSIONS

This Warranty covers Material and Faulty Workmanship defects only.

This Warranty does not cover damage caused by:

- Normal wear and tear due to usage
- Misuse or abusive use of the UNI-MIG, RAZORWELD, UNI-TIG, UNI-PLAS, UNI-FLAME, TECNA, T&R, HIT-8SS & ROTA,
- Failure to follow instructions supplied with the product.
- Failure to clean or improper cleaning of the product
- Failure to maintain the equipment such as regular services etc
- Incorrect voltage or non-authorized electrical connections
- Improper installation
- Use of non-authorized/non-standard parts
- Abnormal product performance caused by any ancillary equipment interference or other external factors
- Failure or any breakage caused by overload, dropping or abusive treatment or use by the customer
- Repair, modifications or other work carried out on the product other than by an Authorized UNI-MIG, RAZORWELD, UNI-TIG, UNI-PLAS, UNI-FLAME, TECNA, T&R, HIT-8SS & ROTA Service Dealer

Unless it is a manufacturing fault, this Warranty does not cover the following parts:

MIG Welding Torches and Consumables to suit, such as:

Gas Nozzles, Gas Diffusers, Contact Tip holder, Contact tip, Swan Necks, Trigger, Handle, Liners, Wire Guide, Drive Roller, Gas Nozzle Spring, Neck Spring, Connector Block, Insulator, Gas Nipple, Cap, Euro Block, Head Assembly, Gas Block, Trigger Spring, Spring Cable Support, Neck Insulator, Shroud Spring, Gun Plug Cover, Lock Nut, Snap On Head, Spring Cap, Ball, Motor 42 Volt, Pot 10K standard, Knob, Drive Roll Seat, Washer, Bow, Ball Bearing, Wire Conduite Nipple, Central Plug, Printed Circuit Board, Gun Plug House, Cable Support, Gas Connector, Handle To Suit PP36 with Knobs, All Xcel-Arc/ Magmaweld Mig Welding Wires & Electrodes, Arc Leads, Welding Cable, Electrode Holder, Earth Clamps

TIG Welding Torches and Consumables to suit, such as:

Tungsten Electrodes, Collet, Collet Body, Alumina Nozzle, Torch Head, Torch Head water Cooled, Torch Head Flexible, Back Caps, Gas Lens, Torch Handle, Cup Gasket, Torch Body Gas Valve, O-ring, All UNI-MIG TIG Welding Rods, All Xcel-Arc/ Magmaweld Electrodes, Arc Leads, Welding Cable, Electrode Holder, Earth Clamps.

PLASMA Cutting Torches and Consumables to suit, such as:

All Cutting Tips, All Diffuser/Swirl Ring, All Electrode, Retaining Caps, Nozzle Springs, All Spacers, All Shield Caps, All Air and Power Cables, All Switches, All O-rings, All Springs, All Circle Guides and Cutting Kits, Torch Bodies, Air Filter Regulator, Arc Leads, Welding Cable, Electrode Holder, Earth Clamps

STRAIGHT LINE CUTTING MACHINES and Consumables to suit, such as:

Hoses, Fittings, Track, Cutting Nozzles.

HIT-8SS Welding Carriage Consumables to suit, such as:

Input Cord, Inter-connecting Cord, Triggering Cable.

This Warranty does not cover products purchased:

- From a non-authorized UNI-MIG, RAZORWELD, UNI-TIG, UNI-PLAS, UNI-FLAME, TECNA, T&R, HIT-8SS & ROTA Dealer (such as purchases from unauthorized retailers and purchases over the Internet from unauthorized local/international sellers or sites such as EBay)
- At an auction;
- From a private seller

Unless it is a manufacturing fault, this Warranty does not apply to any products sold to Hire Companies.

These conditions may only be varied with the written approval of the Directors of Welding Guns Of Australia PTY LTD

REMEMBER TO RETAIN YOUR ORIGINAL INVOICE FOR PROOF OF PURCHASE.



Welding Guns Of Australia Pty Ltd
ABN: 14 001 804 422

PO Box 3033, Lansvale NSW 2166, AUSTRALIA
112 Christina Rd, Villawood, NSW 2163

Phone: (02) 9780 4200

Fax: (02) 9780 4244

Email: sales@unimig.com.au / Web: www.unimig.com.au